

April 2006

The ANCHORLINE

White Rock Power & Sail Squadron



As we enter the month of April and once again switch our clocks to daylight savings time, it's definitely time to start thinking of getting our boats ready for the season and adjusting our priorities to allocate time for on-the-water activities. At the same time, those of us on your squadron bridge and your team of instructors and proctors can reflect back on another successful season of teaching safe boating and exchanging tales with fellow boaters in our community.

Our list (enclosed) of nominees for the incoming Bridge includes a few new names along with a number of incumbents, which should ensure that our squadron's leadership has a mix of new blood coupled with ample experience to ensure that our ship stays afloat.

Our squadron's Annual General Meeting is scheduled to take place at 7:00 p m on Monday, April 24th at Windsor Square. Please plan to attend and welcome in your new Bridge. This is an excellent time to meet other members in your squadron and kick off the summer boating season. I hope to see you there. Our Change of Watch is planned for Saturday, May 13th, and will be held at the Elk's Lodge, 1469 George Street. Details are included on last page. This year we have made an effort to keep the ticket price particularly affordable in an effort to attract greater participation. I strongly recommend that you consider attending, as I know that it will be a fun event and good value for an evening out.

I'd like to pass on a few notes from our District's last monthly Council meeting that I think you'll find of interest:

- CPS-ECP / Transport Canada – New Distress Signaling DVD is complete, in stock and ready to be ordered. Distress signaling DVD is generating a lot of interest from outside organizations.
- Total membership as at February 1, 2006 stands at 32,062. HQ is continually looking into various membership benefits that would benefit existing members but also attract new members. Please feel free to submit ideas.
- Vessel Licensing will no longer be available through Customs Canada – the changeover from Transport Canada to Services Canada is presenting some problems. It is to go into affect on April 1st, 2006, but with no provision initially for doing so electronically or by fax. It appears that vessel licenses will only be available at the Services Canada offices or by mail. Renewal period of 5 years is suggested. Date of Birth of licensee will be required. Details are available on the Transport Canada web site - obs-bsn@tc.gc.ca, or by contacting Mr. Carl Parisien – parisic@tc.gc.ca. See notice on page 5.
- Transport Canada / Canadian Coast Guard has issued a new edition of the 'Safe Boating Guide'.

I encourage everyone to have a look at 'Members Moorings' on the CPS website www.cps-ecp.ca to get the latest on what's happening nationally, www.powersquadron.ca at the district level, or www.whiterocksquadron.org locally. Included in this issue is a questionnaire that is asking for your comments regarding how CPSS should operate in the future to make the organization better serve its members and students. Our District Commander is asking for your input, and all responses will be compiled and presented at the next Governing Board meeting in Toronto in June.

I would like to like to thank all for the opportunity to have served as your commander during the past year. I think that we have an excellent slate of nominees for your incoming Bridge, and trust that you will be pleased with their enthusiasm. And finally, I am looking forward to becoming a backbencher.

John Naylor, AP
Commander

To: The Members of White Rock Squadron:

REPORT OF SQUADRON NOMINATING COMMITTEE

March 1st 2006

1. The Squadron Nominating Committee nominates the following Members for election as Squadron Officers for 2006/2007

Commander Ken Tomkow 3496 Canterbury Dr., Surrey, BC 604-536-9420,
Executive Officer (Lt/C) Gerald Spence 1527 Bishop Rd., White Rock, BC 604-531-9817
Training Officer (Lt/C) Ken Sissons 13915 Marine Dr. White Rock, BC 604-538-2071
Secretary (1st/Lt) Roger Gibb 14943 20A Ave., Surrey, BC 604-535-6702
Treasurer (1st/Lt) Ted MacKinnon 3323 Rosemary Heights Cr., Surrey BC 604-538-7553
Public Relations Officer (1st/Lt) Andrew Pothier 1915 165A St., Surrey, BC 604-536-0430
MAREP Officer (1st/Lt) Ken Penny 15788 Pacific Ave., White Rock, BC 604-531-5602
Membership Officer (1st/Lt) Richard Hepting 15311 Kettle Cres., Surrey, BC 604-576-6670

2. The Squadron Nominating Committee also nominates the following Members for election as Squadron Officers, with the rank of First Lieutenant, who, if elected, will have the duties indicated next to their names assigned to them by the Squadron Executive Committee pursuant to Squadron Regulation 6.2.1(d):

Editor Carlos Fuenzalida 14981 Beachview Ave., Surrey BC 604-535-0369
Communications Linda Spence 1527 Bishop Rd., White Rock BC 604-531-9817
Supply Officer Michael Webb 2372 135A St., Surrey BC 604-531-9232
Cruise Master Barry Baniulis 214-15150 29A Ave., Surrey BC 604-542-0519
Programmes Shirley Shea 14981 Beachview Ave., White Rock 604-288-7089
Historian Gerry Durant 1876 141A Ave., Surrey BC 604-535-3573
Webmaster Harold Hanssen 14334 16A Ave., Surrey BC 604-538-7311
Port Captain Bill Bateman 13235 14th Ave., Surrey, BC 604-536-4507
Asst. Port Captain Peter Ladouceur 14720 31A Ave., Surrey BC 604-542-3036
Member at Large Norm Headrick 2299 169th St., Surrey BC 604-531-7425
Member at Large Marilyn Mitchell 117-5622 16th Ave., Delta BC 604-943-9058

3. The Squadron Nominating Committee also nominates the following Member for appointment by the Members as Auditor of the Squadron:

Auditor Shelley Durant 1876 141A Ave., Surrey BC 604-535-3573

4. The Squadron Nominating Committee also advises that:

(a) the following Member will serve on the Squadron Executive Committee by virtue of his position as immediate Past Commander, and does not require election or appointment:

Past Commander John Naylor 16441 10A Ave., Surrey BC 604-538-2720

b) pursuant to Squadron Regulation 9.14.1, the following Members will serve on the Squadron Nominating Committee for 2007/2008 by virtue of their position, and do not require election or appointment:

P/Cdr John Naylor (Chairman) 16441 10A Ave., Surrey BC 604-538-2720
P/Cdr Ken Penny 15788 Pacific Ave., White Rock, BC 604-531-5602
Cdr Ken Tomkow 3496 Canterbury Dr., Surrey, BC 604-536-9420

Respectfully submitted;

P/Cdr Ken Penny, AP P/Cdr Andrew Pothier P Cdr John Naylor AP
Chairman

Notice of Annual General Meeting to be held at Windsor Square,
1959 152nd Street, Surrey, BC on April 24th 2006 at 1900 hours for the purposes of:

1. Receiving and, if thought fit, approving the reports of the Officers of the Squadron;
 2. Receiving and, if thought fit, approving the Financial Statements of the Squadron for the twelve month period ending March 31, 2006, and the report of the Squadron Auditor thereon;
 3. Electing the Officers of the Squadron;
 4. Appointing the Squadron Auditor; and
 5. Considering such further and other business as may properly come before the Meeting.
- The report of the Squadron Nominating Committee is attached to and forms part of this Notice. Under Squadron Regulation 12.1 any further nominations must be made by way of petition in writing signed by not less than 5 (five) members of this Squadron who shall confirm the consent of their nominee to stand for election. The petition must be filed with the Squadron Secretary not less than 2 (two) days prior to the date of this meeting.

Dated this 26th day of March, 2006

Roger Gibb
Secretary

Change of Watch Ceremony and Dinner

**Place: Elks Hall
1469 George Street
White Rock, B.C.**

Date: Saturday, May 13

Time: 1800 hours

Open Bar. Music.

Price: \$30.00 per person

**For tickets contact: Ken Tomkow, 536-9420
Gerry Spence, 531-9817**



Would anyone willing to help with the evening please contact:

Ken Tomkow at 604-536-9420

The more we have helping the easier it is to put on.

Training Officer's Report.....



With our spring training program nearing completion, we can look back on another successful year teaching and promoting safer boating. For the fall and spring sessions we had a total of 225 students enrolled in 13 classes. We would like to express our thanks to the instructors, proctors, and other volunteers, without whose help our training program would have been impossible. We estimate that 30 White Rock Squadron members contributed a total of more than 800 hours of their time to this year's training program. If you would like to help next year, please contact us. Your reward will be knowing you contributed to improving boating safety, and you will find by sharing your knowledge, you will gain almost as much in return through interaction with our students and teachers.

This year saw the introduction of a new "Navigating with GPS" course, and the addition of student CD's for both the GPS and Marine Radio courses. These CD's contain information useful to the student learning the subject, and also allow the student to interact with a VHF radio or GPS unit simulator running on their own computers.

Next year we will begin teaching the new "Boating" course. With many volunteers from across Canada working on new courses and improvements to existing courses, CPS courses will continuously improve and add to the learning experience. White Rock Squadron continued to demonstrate commitment to training by purchasing a third video projector this year, acquiring the new Bateman trophy to be presented to the Piloting student with highest marks, and ordering a flare demonstration kit to be delivered before the fall classes commence.

Gerry Spence,
Training Officer

Quick-Release Man-Overboard Pole Holder

Kevin Dean has installed a new M.O.B. pole holder on his Morgan 32, *Via Sophia*. It prevents inadvertent or accidental pole deployment while assuring quick and effortless release when the pole is needed. Just push on the pole or float, and over it goes.

The holder is made up of a slotted, thin-wall PVC tube; a mounting board; and a couple of all-stainless hose clamps. An optional safety ring, cut from a pipe cap or pipe coupler, can easily be added.

In another issue, we will look at ways of securing the upper, flag end of the man-overboard pole.

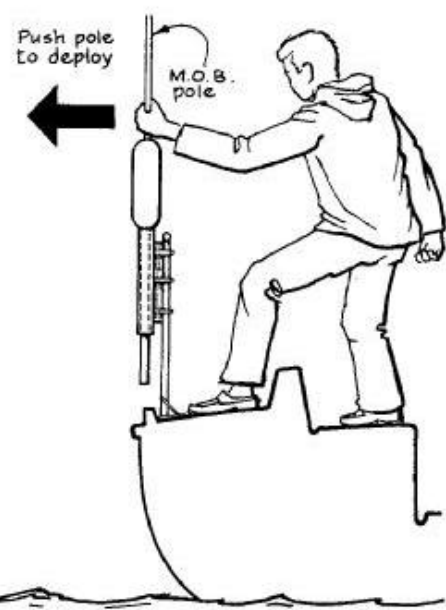
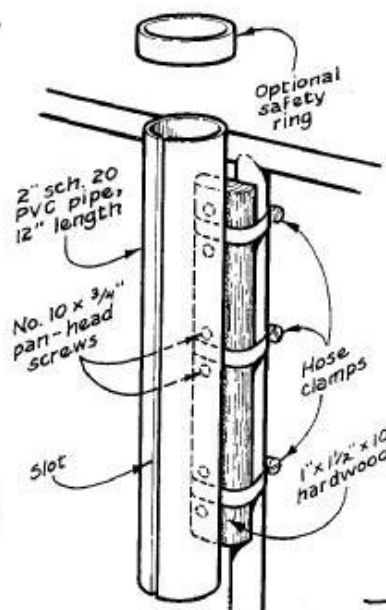
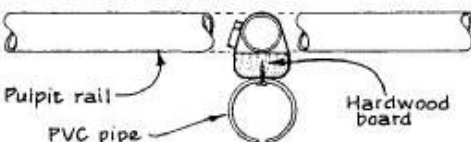

The idea described above was first printed in the December 1995 issue of *Cruising World WORKBENCH*. Kevin says the system is still operational even though he has never had to use it in an emergency.

Important !!!



Government
of Canada

ATTENTION BOAT OWNERS

Transport Canada would like to inform pleasure craft owners that starting on April 1, 2006, * you can apply for a Pleasure Craft Licence at all 320 Service Canada Centres across the country. For the location nearest you, visit www.servicecanada.gc.ca or call 1 800 O-Canada (1-800-622-6232) TTY 1-800-926-9105.

Pleasure craft of 12m or less and powered by an engine of 10 hp (7.5 kW) or more must display a licence number. This number allows search and rescue personnel and other agencies to identify boats quickly in emergencies.

Transport Canada is the federal government department responsible for overseeing boating safety. For more information about boating safety visit www.boatingsafety.gc.ca.

As of April 1, 2006, Canada Border Services Agency will no longer be issuing licences.

Water Safety Tips...

- ? Learn to swim. The best thing anyone can do to stay safe in and around water is to learn to swim. This includes anyone participating in any boating activity. And... never swim alone.
- ? Read and obey all rules and posted signs.
- ? Don't try to swim against a current if caught in one. Swim gradually out of the current, by swimming across it.
- ? Stay away from pilings, piers and diving platforms when in the water.
- ? Don't rely on flotation devices, such as rafts, you may lose them in the water.
- ? Supervise children closely, even when lifeguards are present.
- ? Swim parallel to shore if you wish to swim long distances.
- ? Alcohol and boating do not mix. Alcohol impairs your judgment, balance and coordination... over 50 percent of drownings result from boating incidents involving alcohol.
- ? For the same reasons it is dangerous to operate an automobile while under the influence of alcohol, people should not operate a boat while drinking alcohol.
- ? Look for the label: Use Coast Guard-approved life jackets for yourself and your passengers when boating and fishing.
- ? Develop a float plan. Anytime you go out in a boat, give a responsible person details about where you will be and how long you will be gone. This is important because if the boat is delayed because of an emergency, becomes lost, or encounters other problems, you want help to be able to reach you.
- ? Watch the weather: Know local weather conditions and prepare for electrical storms. Watch local news programs. Stop boating as soon as you see or hear a storm

Please participate by sending your response !!

CPS-ECP PLANNING COMMITTEE REPORT

Answers to the following questions are required to assist in determining our future course of action relating to the Approved Planning Committee Report of 2005.

1. How do you as squadron members feel about the possibility of a name change?
2. How do you feel about our logos?
3. How do you feel about the uniform issue?
 - i. Should we have any uniforms?
 - ii. Should we reduce the number from 9 to 4?
4. How do you feel about our use of ranks to designate officer's positions?
 - i. Should we move to more corporate identities for our governing board members?
5. How do you feel about restructuring our membership requirements to make our organization more accessible for training?
6. How do you feel about rewarding our volunteers with specialty items or discounts on our stores items?

Please email comments, suggestions and other results to jgnaylor@shaw.ca before April 22, 2006.

Thank You.



2006 Cruising Schedule

Please select cruises from the list below and contact Barry at:

Barry Baniulis
214-15150-29A Avenue
Surrey, BC V4P 1H1
604-542-0519
email: irishromy@shaw.ca

Join us for fun and fellowship happy hours, potlucks, dinghy explorations, crib tournaments.....
Marina moorage is becoming very tight in the summer months. Your immediate attention is requested.

Easter	April 14 - 15	Port Sydney Marina 250-655-3711
Victoria Day	May 20 - 21	Telegraph Harbor Marina 250-246-9511
Canada Day	July 1 - 2	Ganges Marina 250-537-5242
Extended Cruise	July 29 - August 13	Desolation Sound North - Tentative schedule below
Labour Day	Sept 2 - 3	Maple Bay Marina 250-746-8482

Mark these on your calendar . Please make reservations directly with the marina to secure berth. Indicate you are with the White Rock Power and Sail Squadron.

Reservations at these marinas may be made by VHF radio on channel 66A.

Extended Cruise to Desolation Sound

Saturday, July 29	Meet off Point Roberts at 7 am traveling to Egmont – about 85 miles – at dock
Sunday, July 30	To Princess Louisa – about 35 miles – slack at 9:45 am or 3:30 pm – at dock, hopefully
Monday, July 31	Layover day
Tuesday, August 1	Leave Princess Louisa at slack 6 am or 12:30 pm – to Refuge Cove – about 75 miles – at dock
Wednesday, August 2	To Big Bay community dock– Gilliard slack at noon
Thursday, August 3	To Shoal Bay – dock – about 8 miles – slack at 1:15 pm
Friday, August 4	To Blind Channel – about 12 miles – at dock – a group dinner out??
Saturday, August 5	To Octopus Islands – about 28 miles- Okisollo slack at 4:40 pm – anchoring
Sunday, August 6	Layover day
Monday, August 7	To Gorge Harbor – Beazley slack at 8 am or option of Hole in the Wall slack at 9:20 am. At dock - Group dinner out????
Tuesday, August 8	To Squirrel Cove – about 20 miles – anchoring
Wednesday, August 9	To Prideaux/Tenedoes – about 15 miles – anchoring
Thursday, August 10	To Smugglers Cove – about 60 miles – anchoring
Friday, August 11	To Nanaimo – NewCastle Marine Park – anchoring/dock – a group dinner at dinghy dock pub ???
Saturday, August 12	Dodds Narrows slack at 12:30 pm – to Montague Marine Park – about 30 miles
Sunday, August 13	Return home to respective marinas

This is a **tentative schedule**, subject to a wide variety of considerations - weather being a major factor.

Monthly Meetings... come and meet your bridge...

If you would like to attend one of our Squadron meetings, they are held on the third Monday of every month, at the **ABC Country Restaurant**, 2160 King George Hwy. Dinner starts at 6:30 PM, meeting starts at 7:15 PM.
Please call one of the bridge members to confirm...

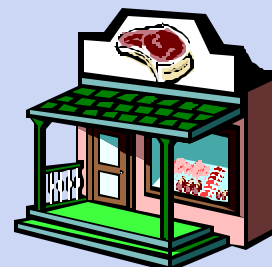

Find us on the Internet
www.whiterocksquadron.org

Contributions should be sent:

Attn: Editor
Box 499
800-15355 24th Avenue
Surrey, BC V4A 2H9

Phone: 604-535-0369
Fax: 604-535-0369
Email: carlosf@shaw.ca

Calendar of Events

April 6 - Social evening with Crescent Beach Coast Guard Auxiliary. 7:30 PM, Windsor Square, 1959 - 152nd Street, Surrey, B.C.

April 24 -Squadron AGM. 7:00 PM, Windsor Square, 1959 - 152nd Street, Surrey, B.C.

May 13 - Squadron Change of Watch. Details on pg. 3

May 30 -Course graduations, Crescent Beach Yacht Club. (To be confirmed)

Ship Safety Bulletin # 03/2006 has been issued cautioning boat owners, dealers, and repair shops **not to use automotive parts on boats**, and ensure the parts on boats are ignition protected. A seven minute film, "Boom! Up She Went" is available at http://ram.canadacast.ca/asxgen/transport/boom_eng/BOOMEN.wmv

SAFE BOATING AWARENESS WEEK, MAY 20 - MAY 26, 2006



Safe Boating Awareness Week will take place across Canada from **May 20 to May 26, 2006**. The purpose of this initiative is to promote a wide range of safe boating practices to the estimated 7 million recreational boaters in Canada.

This initiative is promoted by the Canadian Safe Boating Council, a non-profit organization and its members and partners from all areas of the marine community including manufacturers, boating education organizations, water safety and marine law enforcement sectors. The goal is to ensure that the millions of Canadians who head out on the waters in canoes and kayaks, sailboards and sailboats, fishing boats, personal watercraft, power boats and cruisers are equipped with the knowledge for a safe day on the water.

Catch the spirit!

Canadian Power & Sail Squadrons and Spirit of Canada Ocean Challenges have joined forces to increase public awareness for safe boating.

Canadian Sailing sensation, Derek Hatfield placed third in the 2002 Around Alone single-handed race. He is now preparing to take Canada's name to the world's oceans again. In 2006, aboard the new Open 60, Spirit of Canada, Derek will compete in the 5-Oceans Challenge, the single-handed, around the world race.

As the excitement builds to 2006, CPS-ECP and Spirit of Canada will embark on a series of initiatives, focusing on boating safety, environmental responsibility and youth education.

